



18506/177-219 Mitchell Road Erskineville NSW

1  1  1 

Filled with natural light, this 5th floor apartment captures city skyline views from the north facing terrace. Providing low maintenance urban living, open plan layout, with a study area suitable from home office, overnight guests or nursery & highly prized security parking, an inspection is a must!

Spacious open plan living & dining area
 Generous entertainer's terrace
 Modern gas kitchen w/ s/s appliances & plenty of storage
 Master bedroom w/ BIR & terrace access
 Separate study, perfect for home office or nursery
 Stylish bathroom w/ tub & laundry facilities
 Security intercom, direct access to secure basement parking via lift & 24/7 onsite security
 Strata levies approx. \$1630/quarter
 Current market rent \$780/week

Price : \$ 812,000
Building Size : 83 sqm
Land Size : 83 sqm
View : <https://www.parkproperties.com.au/sale/nsw/inner-west/erskineville/residential/apartment/7516742>



Melissah McCaffery J P
02 9565 5333



Rebecca Voncina
02 9565 5333

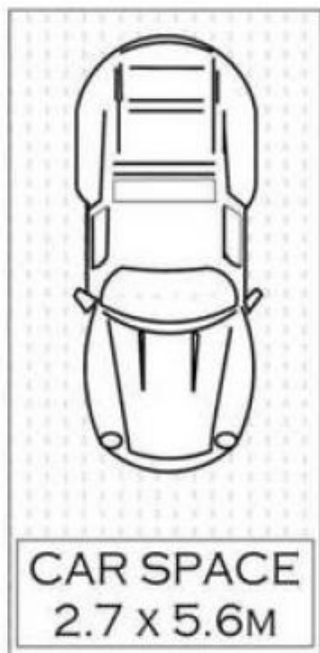

LEVEL FIVE



NOTE :- ONE SECURE CAR SPACE



parkproperties
(Aust) Pty Ltd

PLANS SHOWN ONLY INDICATIVE OF LAYOUT. DIMENSIONS ARE APPROXIMATE.
Floor plans by www.realestatemarketingaustralia.com.au
Ref. No: 7425

18506/177-219 MITCHELL ROAD

ERSKINEVILLE